

Bobine ②	Curent alternativ (V)							Curent continuu (V)			Conexiune Electrica	Conector
	12	24	48	110	220 230	240	380	12	24	48		
Seria 2 Latime 30	20A	20B	20C	20D	20E	20F	20G	200	201	202	DIN 43650A	PG9 code 10349000
Seria 5 Latime 36	52A	52B	52C	52D	52E	52F	52G	520	521	522	DIN 43650A	PG11 code 10349001

Descriere
Clasa izolare
Seria 2 =F Seria 5=H
Toleranta voltaj
CA +15% -10%
CC ± 10%
Clasa protectie
IP65 cu conectorul montat
IP00 fara conector

Optiuni
Clasa H izolare (series 2)
Cablul atasat
Tensiuni la cerere
Bobine certificate

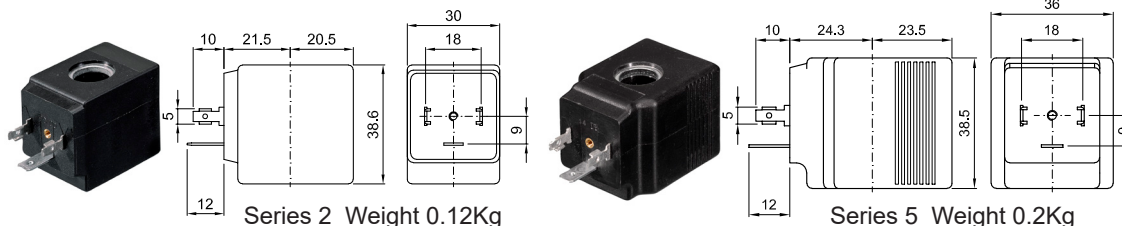

Piese schimb

1. Piulita fixare bobina
2. Bobina
3. Ansamblu garnitura
4. Tub armatura cu miez
5. Membrana
6. Speed control valve
7. Reductor anti lovitura
ciocan Ø0.8-Ø1.2-Ø1.5
(G2"1/2-3")

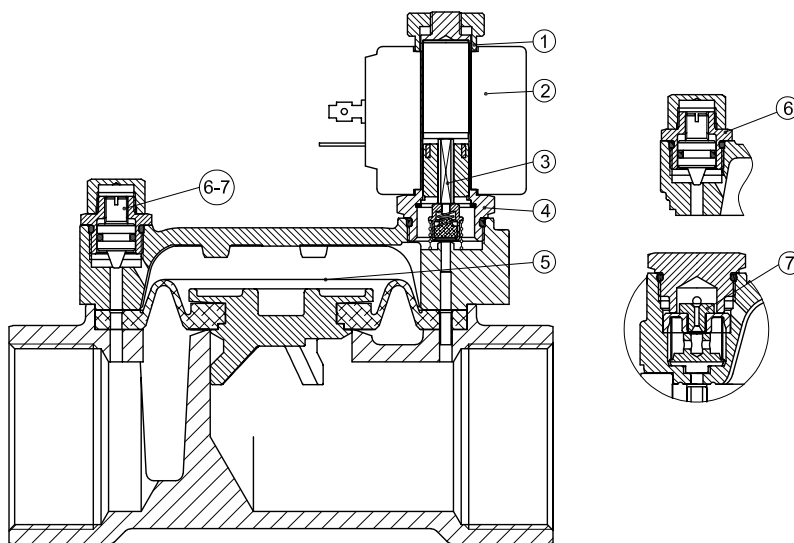

Dimensiuni

COEXIUNE	a	b	c	d	e	f	greutate Kg
G1"1/4	142	105	28	102	21	30	3.00
G1"1/2	142	105	28	102	21	30	2.85
G2"	158	119	35	119	21	30	4.30
G2"1/2	226	135	51	169	21	30	11.7
G3"	226	135	51	169	21	30	9.9